

Tadiran Lithium Battery Packs for Long Term Ocean Deployments

Lee Gordon
Doppler Ltd.
858-486-4077
lee@dopplerltd.com

Long Term Ocean Deployments

- Duration: weeks to years
- Instruments alternate low power standby and high power operation
- Instrumentation is often designed for alkaline battery packs, then investigators decide they want more



*Alkaline Pack for a
Doppler Profiler*



*Replacement PulsesPlus
Lithium Pack With 3x the
Capacity*

Voltage Curves for a Typical Doppler Profiler Deployment

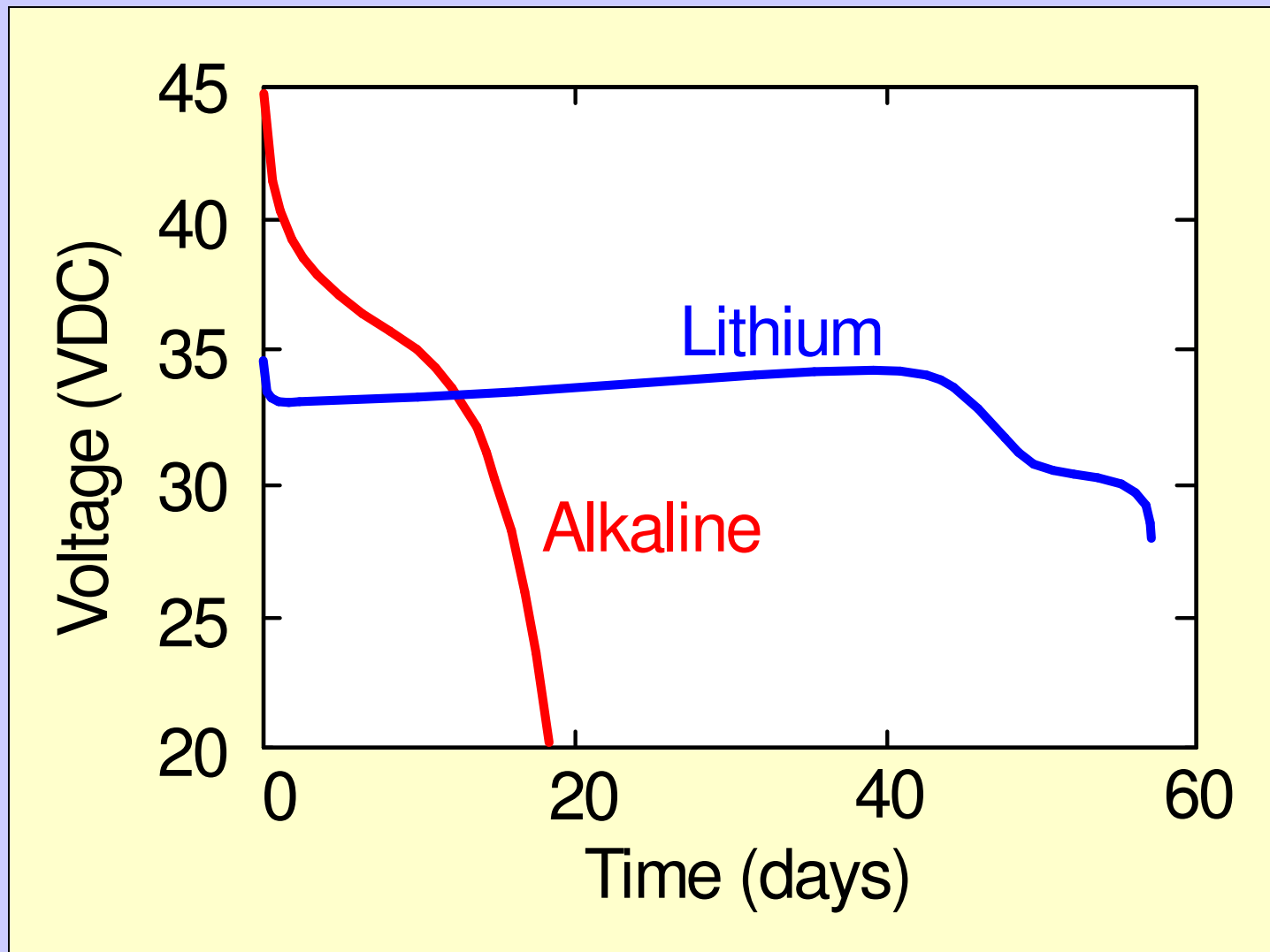

Everything about the deployment setup is the same, only the duration changes.

Capacity vs. Duration @ 20°C

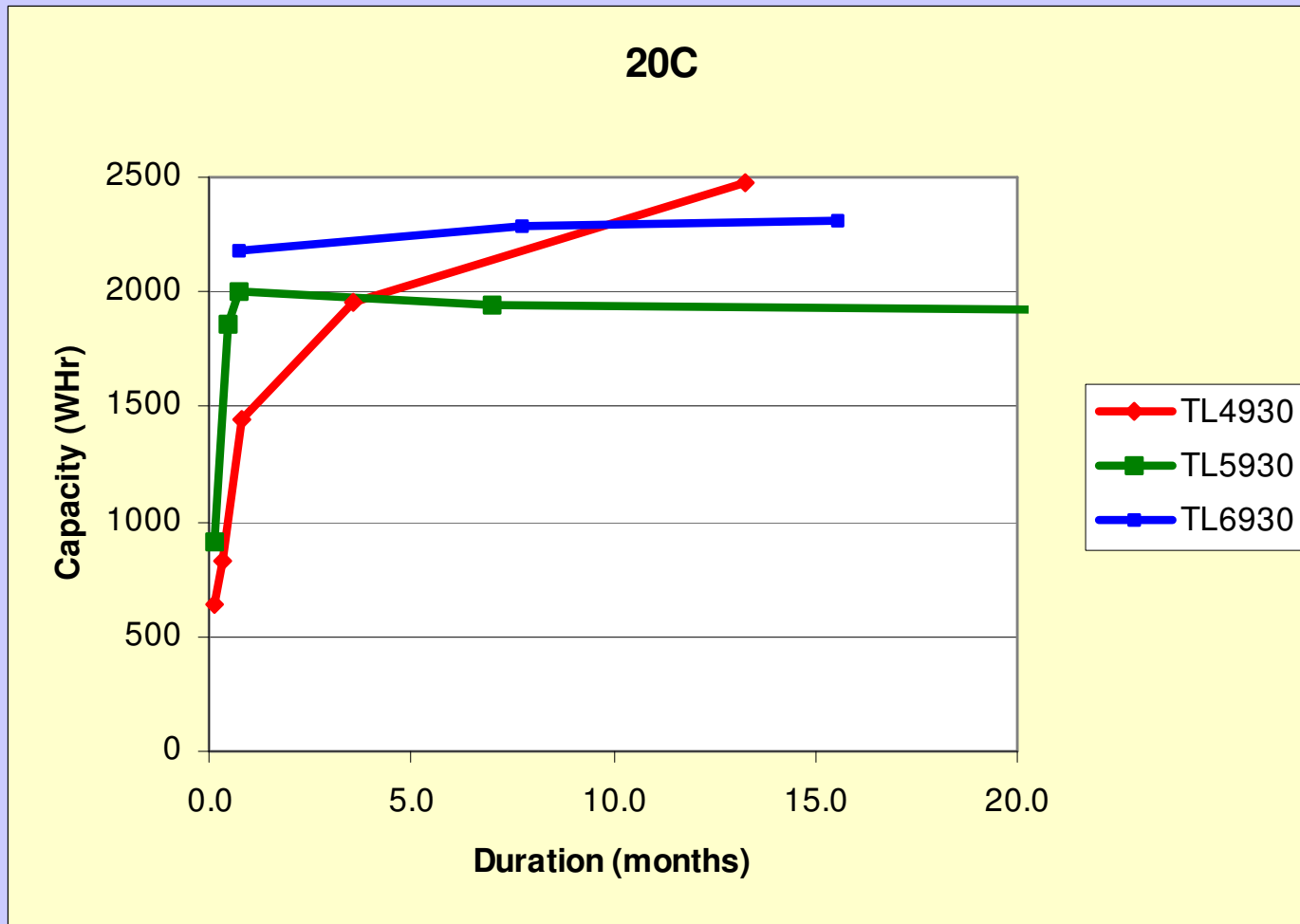

*TL6930
D Primary Cell*

Capacity depends on current, which depends on duration (shorter duration deployments using higher current)

Capacity vs. Duration @ 0°C

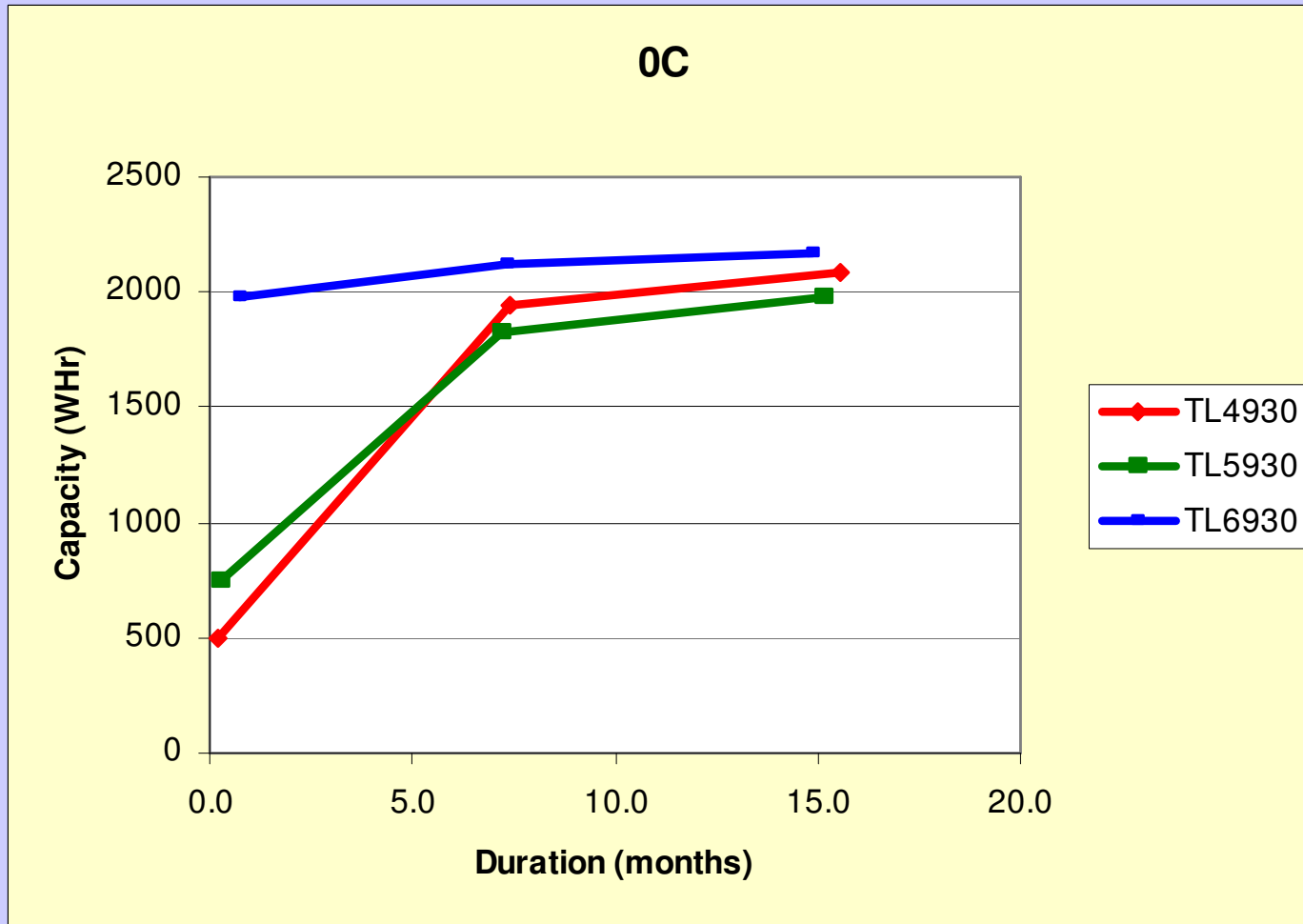

*TL6930
D Primary Cell*

Capacity vs. Temperature

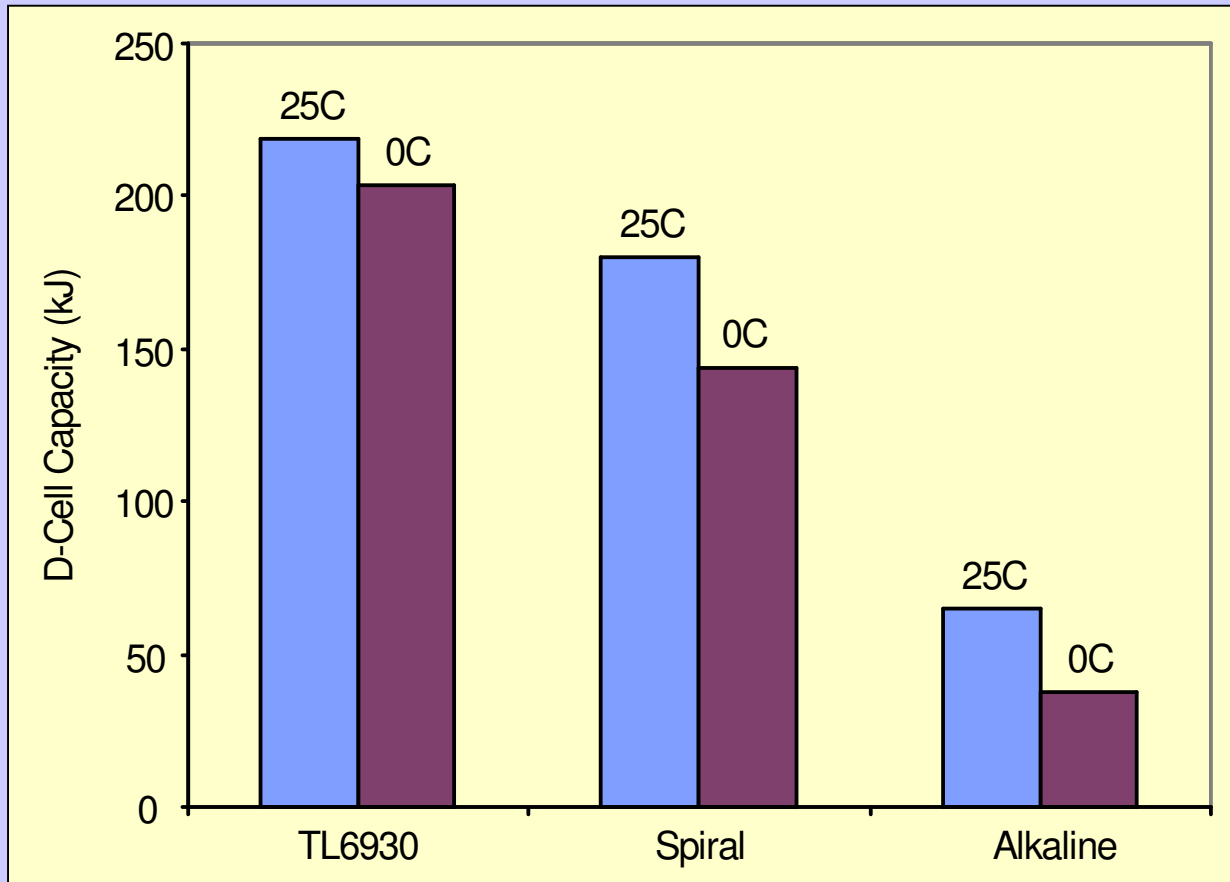

TL6930
D Primary Cell

TL6930 self discharge at 25°C is 0.7% while spiral and alkaline cells have 3% self discharge.

Hybrid Layer Capacitors (HLCs): Capacitors or Rechargeable Lithium Cells?

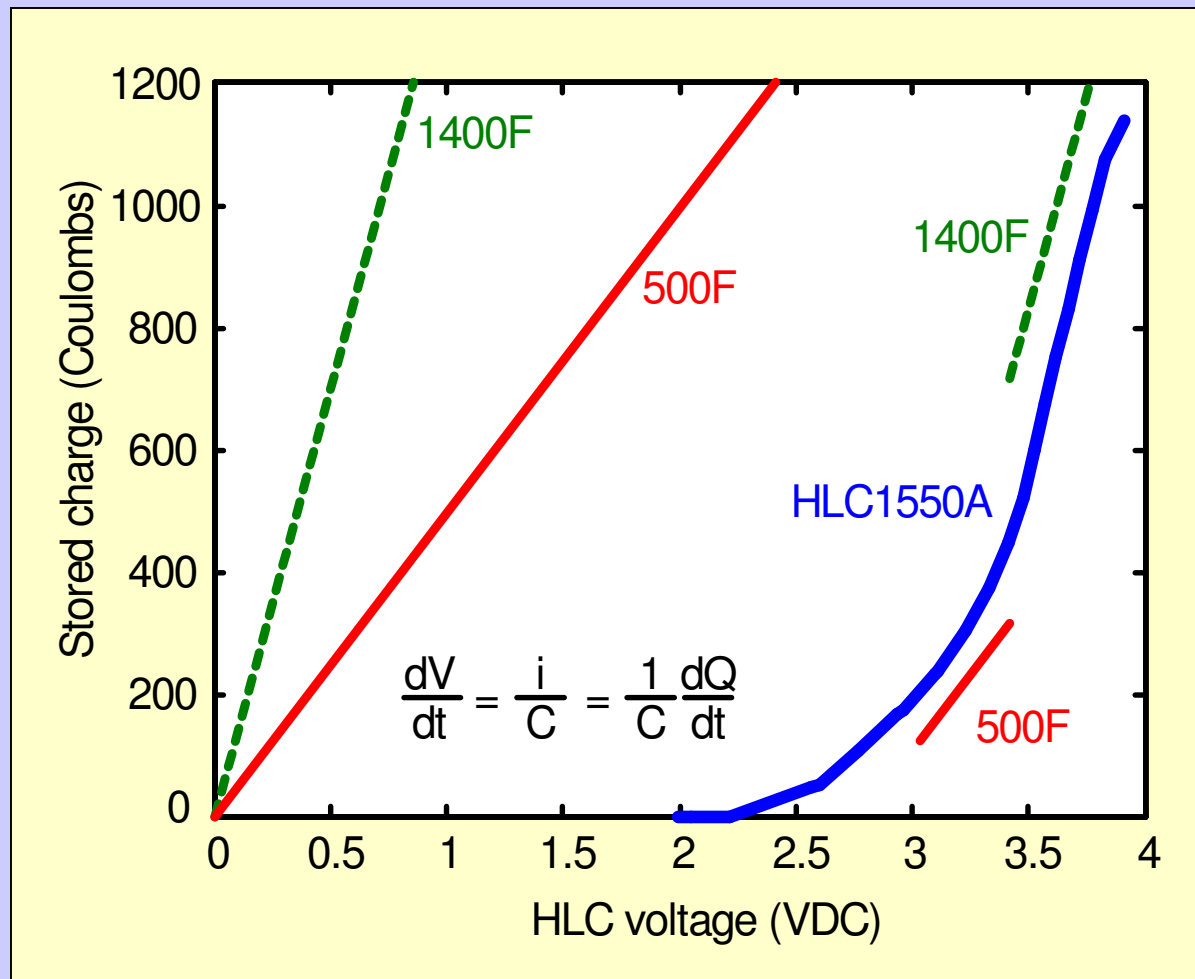

HLCs are rechargeable lithium cells, but over narrow voltage ranges, they behave like high-value capacitors.



*HLC1550A (AA)
~1 A 10 min 3.9-3.5 VDC*



*HLC1520A (0.4 AA)
~0.25 A 10 min 3.9-3.5 VDC*

Voltage Curves for a Typical Doppler Profiler Deployment

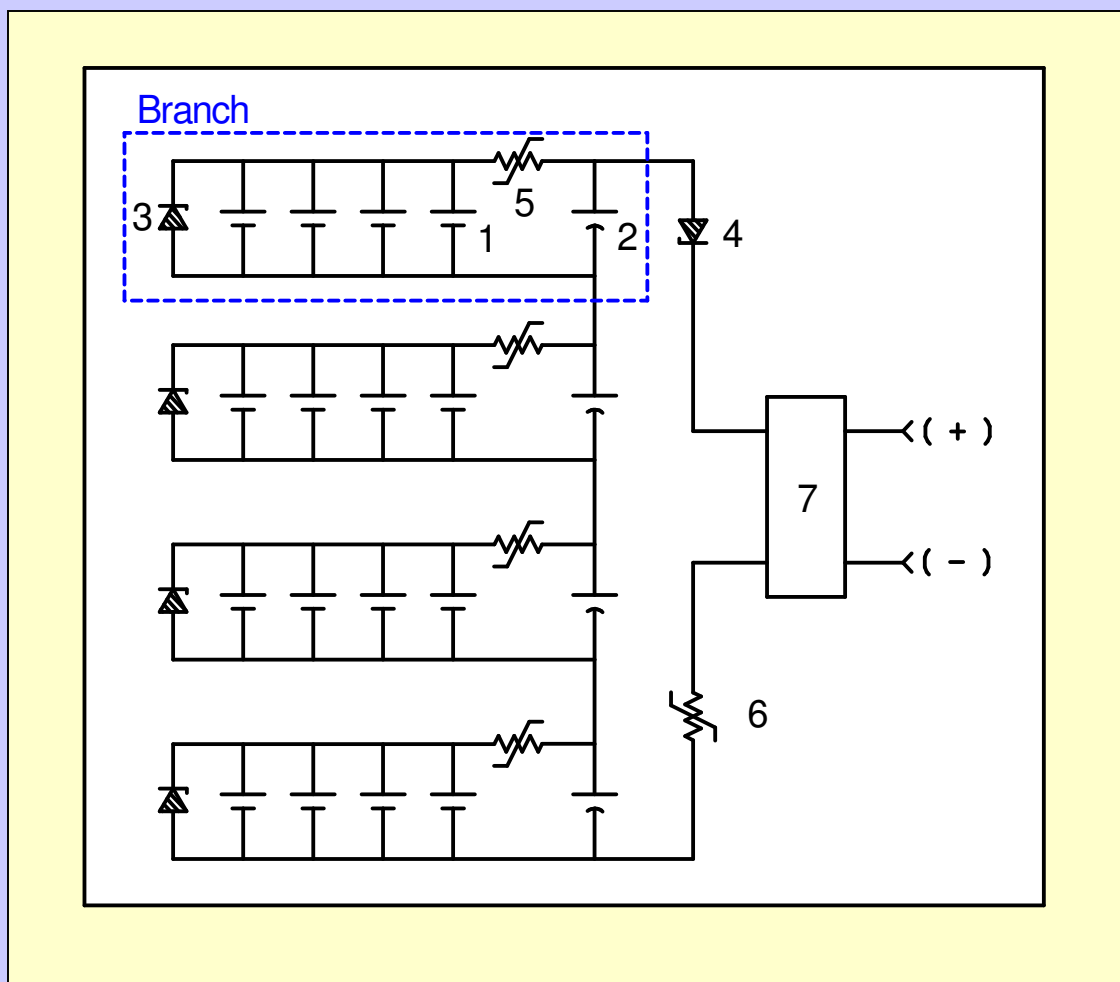

Schematic of a typical PulsesPlus battery pack.

- 1: Primary lithium cells
- 2: HLC
- 3,4: Schottky diode
- 5,6: PTC (positive temperature coefficient thermistor)
- 7: Voltage cut-off circuit

*Cells are organized by **branches** instead of **strings**. A branch holds primary cells, wired in parallel, which charge one or more HLCs.*

Tadiran PulsesPlus cells and packs have no fuses. PTCs protect like fuses that reset automatically when you remove the overload.

Cutoff circuit

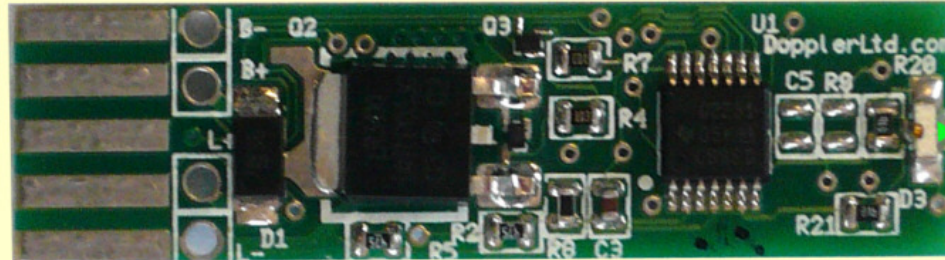

- *Turns off the pack when it is about 97% depleted to prevent reverse currents in branches. The pack holds the remaining charge for more than a decade.*
- *Uses insignificant battery power (much less than the battery pack's self discharge).*
- *Protects against short circuits (but not too hastily!). It cuts off the pack after 100 μ s at >8 A and turns the pack back on when the load is removed.*
- *Provides an LED status indicator (pack OK and new, used, or depleted). Simply short the pack to run this test.*
- *Internally records voltage and temperature to provided estimates of how much of the pack's capacity has been consumed.*

This circuit is primarily useful for production ocean instrumentation. If you are confident you can recover your system before the pack depletes, you do not need one.

Model Schematic

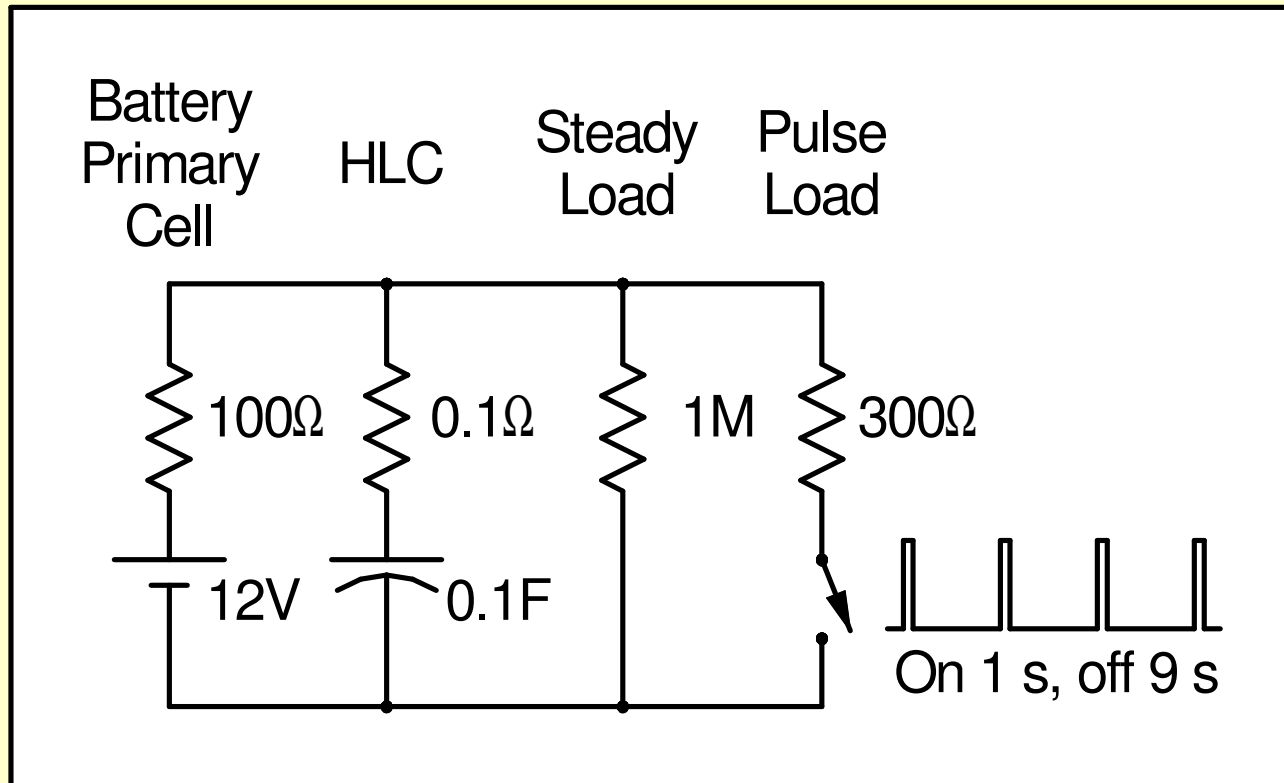

This model is not intended to reproduce a specific battery pack, but rather is intended to illustrate how HLCs enable the pack to supply more of its capacity to the instrument as opposed to internal dissipation.

Model Results: Comparison With & Without the HLC

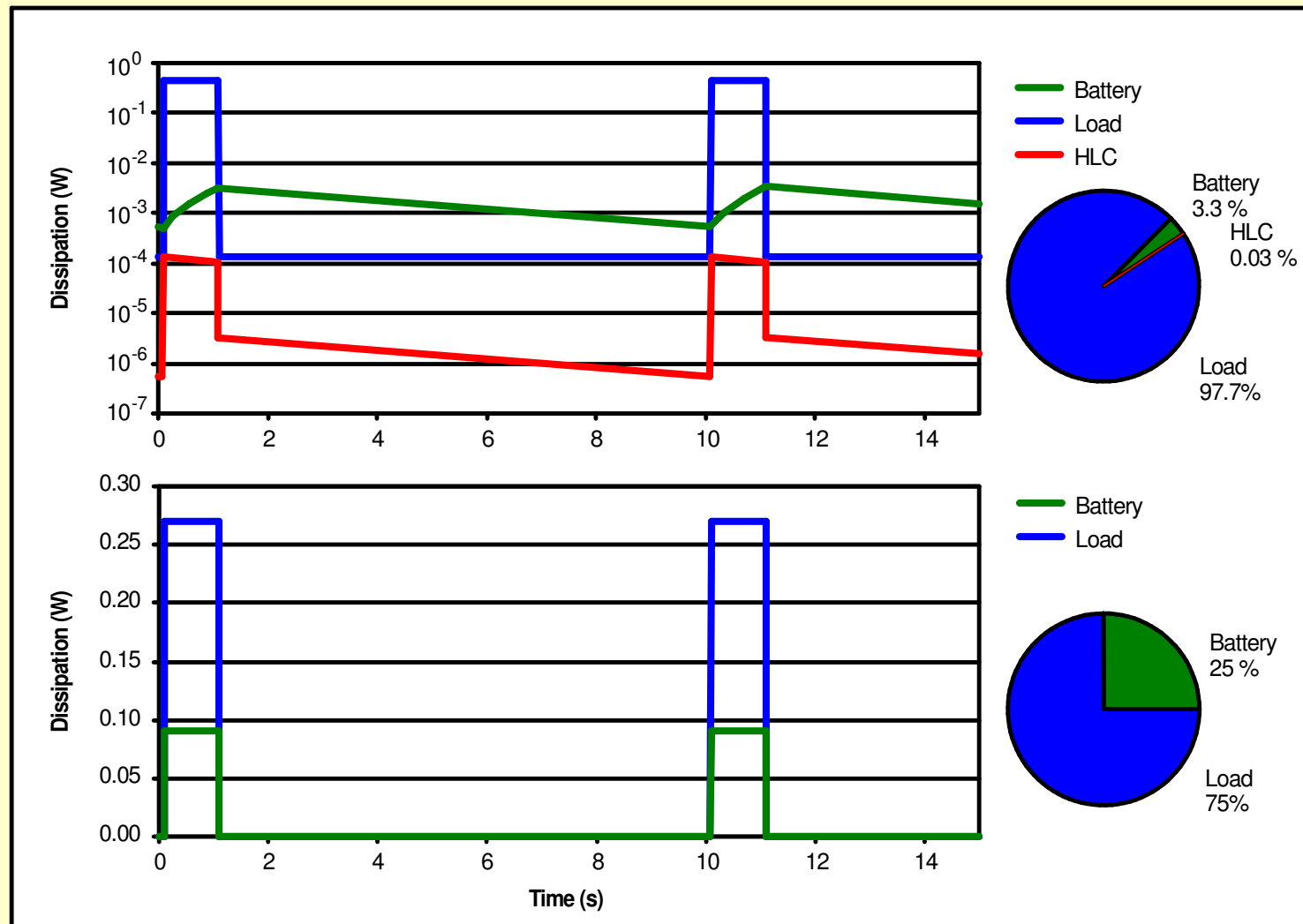

Without the HLCs, 25% of the battery capacity is dissipated by the primary cell's internal resistor. With the HLCs, the internal dissipation drops to 3% and most of the energy goes to the instrument.

Differences Between Low Current and High Current Primary Cells

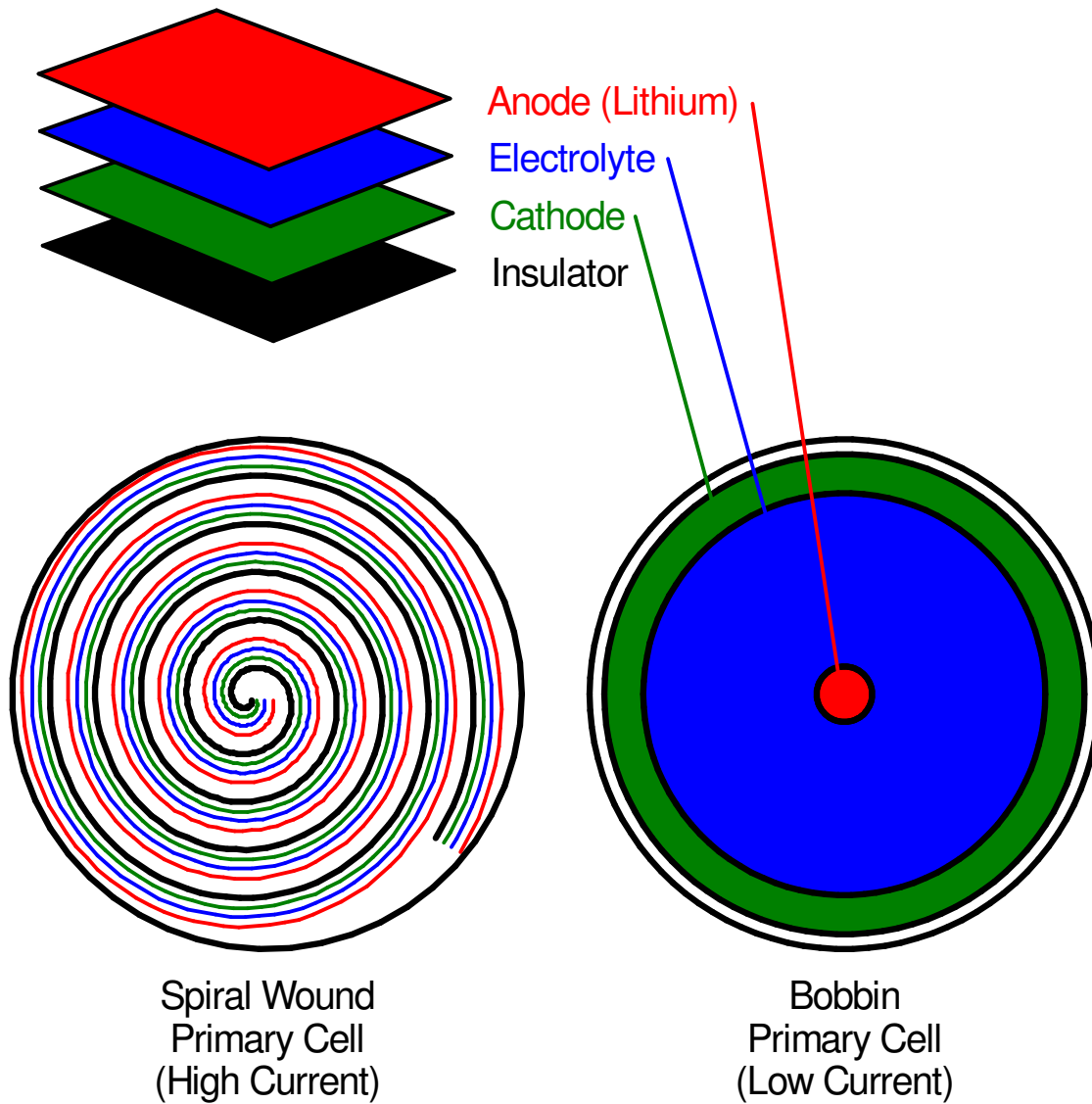

Bobbin cells are simpler, less expensive and, because they hold more lithium, they store more energy. Spiral-wound cells supply high currents by building the battery in sheets. The large surface area also increases self-discharge and increases the chance of shorts between the cathode and anode. The ability to source high currents mean that shorts can become explosive.

Hermetic Seal Prevents Leakage and Outgassing



*Glass seal between
anode and lid*



*Laser weld between
lid and can*

Pack Mechanical Design

Lithium Packs need just a little more room, so plan ahead

