

CUSTOMER CONNECTION	
LABEL	CONN.
A	1" F QRC
B	1" M QRC
D	3/4" F QRC
D3	1/2" F QRC
P-AUX	1/2" M QRC
R-AUX	3/4" M QRC
FP	1" M QRC

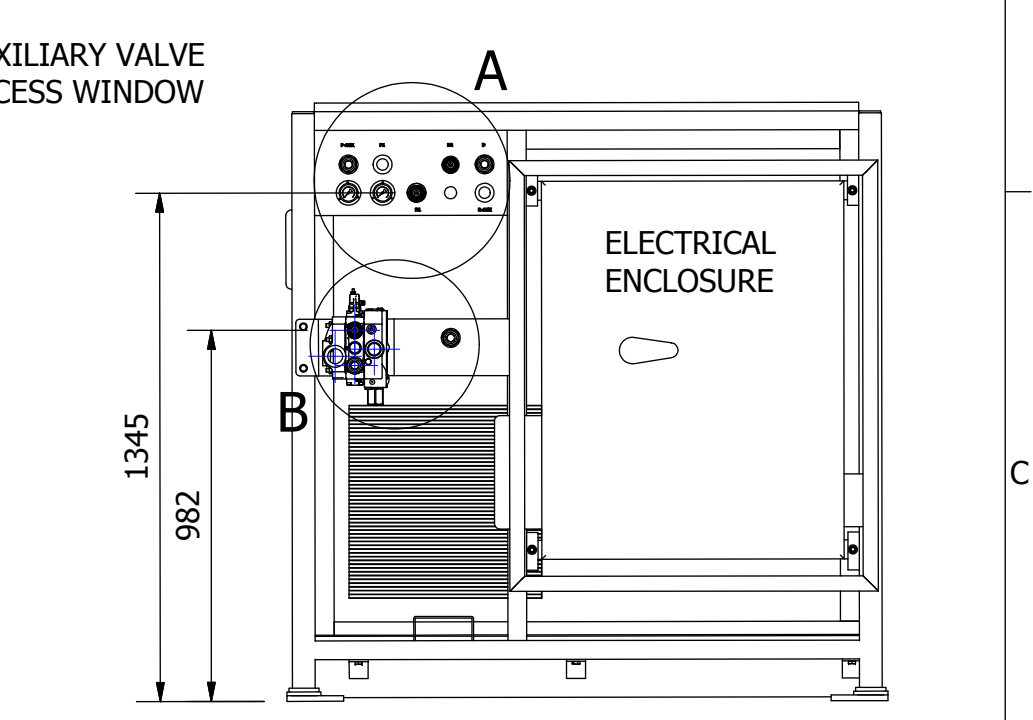
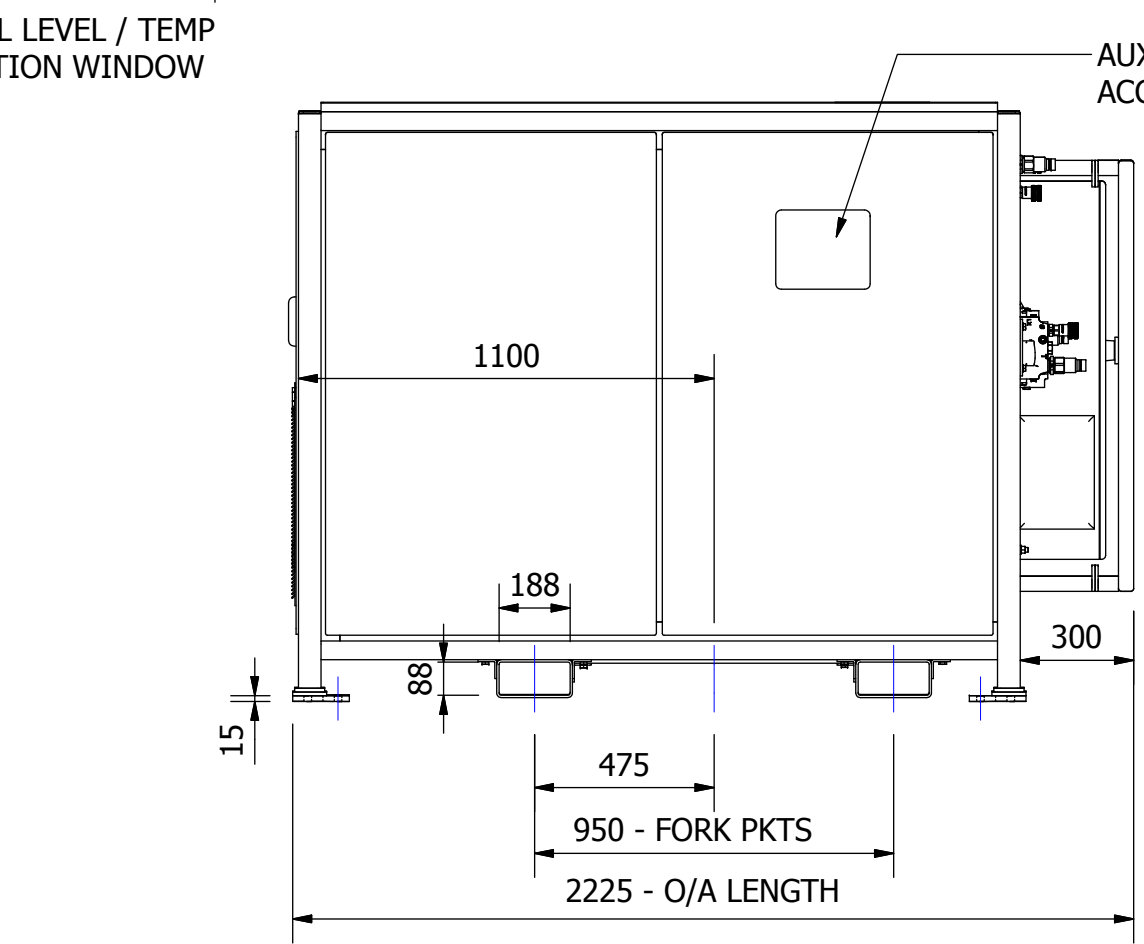
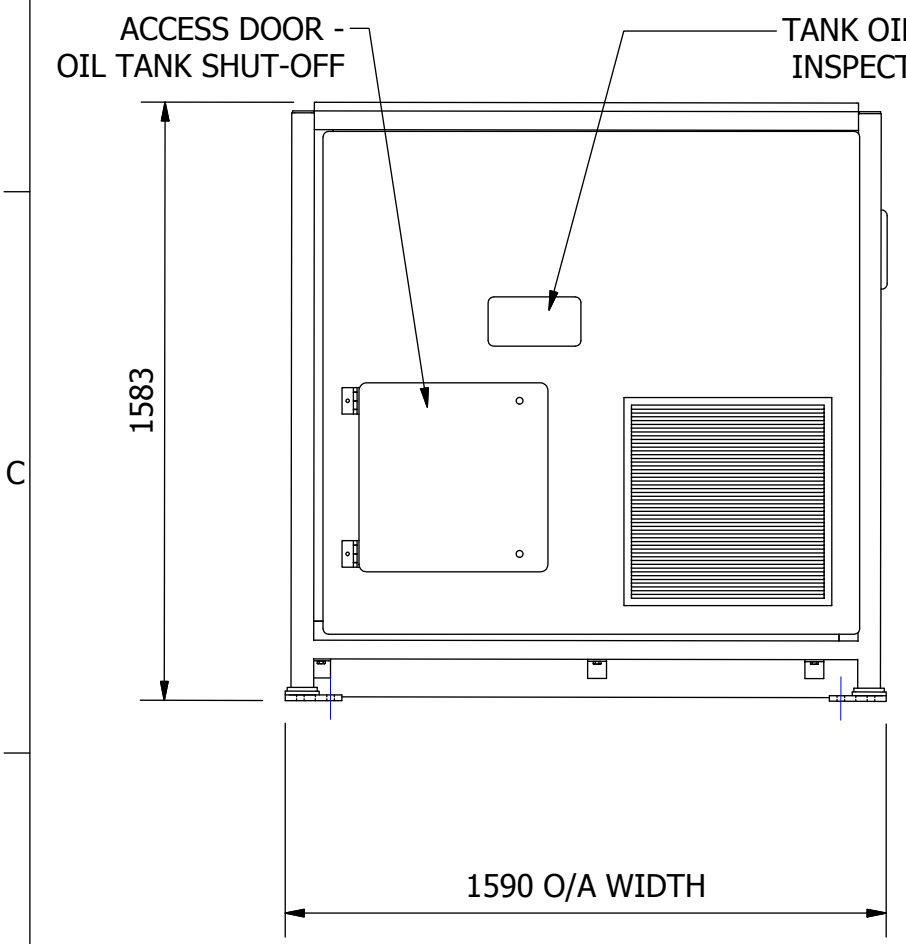

FOR PARTS LIST - SEE BoM-GP0011

REVISION No/		MATERIAL	TOLERANCE UNLESS STATED OTHERWISE	ALL INFORMATION CONTAINED ON THIS DRAWING IS CONFIDENTIAL AND MAY NOT BE USED OR DIVULGED TO A THIRD PARTY WITHOUT WRITTEN PERMISSION FROM LEBUS INTERNATIONAL ENGINEERS LTD.		LEBUS INTERNATIONAL ENGINEERS Ltd.			
3rd ANGLE PROJECTION		FINISH	SURFACE ROUGHNESS MICRONS AT UNLESS STATED OTHERWISE			DATE 01.04.15	DRAWN D.PERKINS	CHECKED JB	CERT'D
		WELD PROCEDURE	DIMS IN MM	SCALE	TITLE 55 kW HYDRAULIC POWER UNIT		PROJECT	DRG No GA-0177-SIO	ISSUE 01